

Assembly dimensions

pump model	feed capacity cm ³ /rev	A mm	B mm	C mm	D øh11 mm	weight ca. without coupling kg	max.counter- pressure at outlet bar
GMZ51D	0,05	186	84	12	105	8	80
GMD11D	0,1	187	85	12	105	8,1	80
GMD31D	0,3	192	90	12	105	8,4	80
GMD61D	0,6	188,5	86,5	14	105	8,2	80
GM121D	1,2	191,9	89,9	14	105	8,4	80
GM301D	3	202,3	100,3	14	105	9,1	80
GM601D	6	189,5	87,5	22,5	120	9,5	80
GMA21D	12	198	96	22,5	120	10,1	80
GMB01D	20	208,3	106,3	22,5	120	11	80

Example: GM601D-RML-110Z is a Barmag gear metering pump with feed capacity of 6 cm³/rev, of rust-and acid-proof steel, with magnetic coupling and buffer fluid.

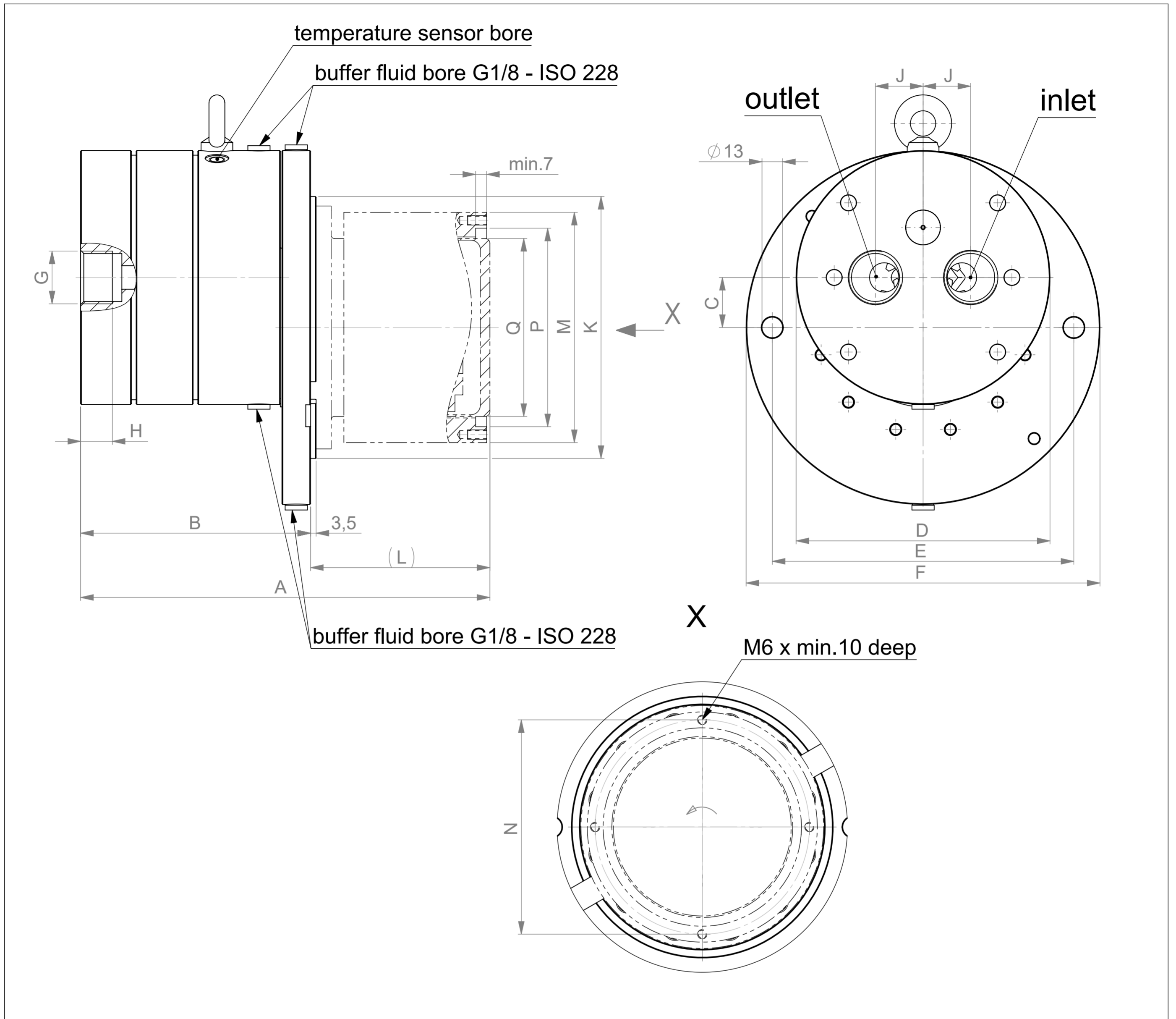

Assembly dimensions

pump model	feed capacity cm ³ /rev	A	B	C	D	E	F	G	H	J	K	L	M	N	P	Q	weight ca. without coupling kg	max.counter- pressure at outlet bar
		mm	mm	mm	øh11 mm	mm	mm	mm	ISO228	mm	mm	ø-0.05 mm	mm	ø mm	ø mm	øH7 mm		
GMV51D	50	257,9	144,9	31,5	160	190	223	G1	20	30	165	113	145	135	125	112,1	26	80
GMH10D	100	293,7	180,7	31,5	160	190	223	G1	20	30	165	113	145	135	125	112,1	31	80
GMH15D	150	344,1	208,1	40	200	250	280	G1 1/2	24	35	190	136	170	160	150	136,9	58,6	80
GMH20D	200	368,8	232,8	40	200	250	280	G1 1/2	24	35	190	136	170	160	150	136,9	64,1	80

Example: GMV51D-RML-110Z is a Barmag gear metering pump with feed capacity of 50 cm³/rev, of rust-and acid-proof steel, with magnetic coupling and buffer fluid.